

VSL CT Stress Bar Systems

DESIGNED BY VSL

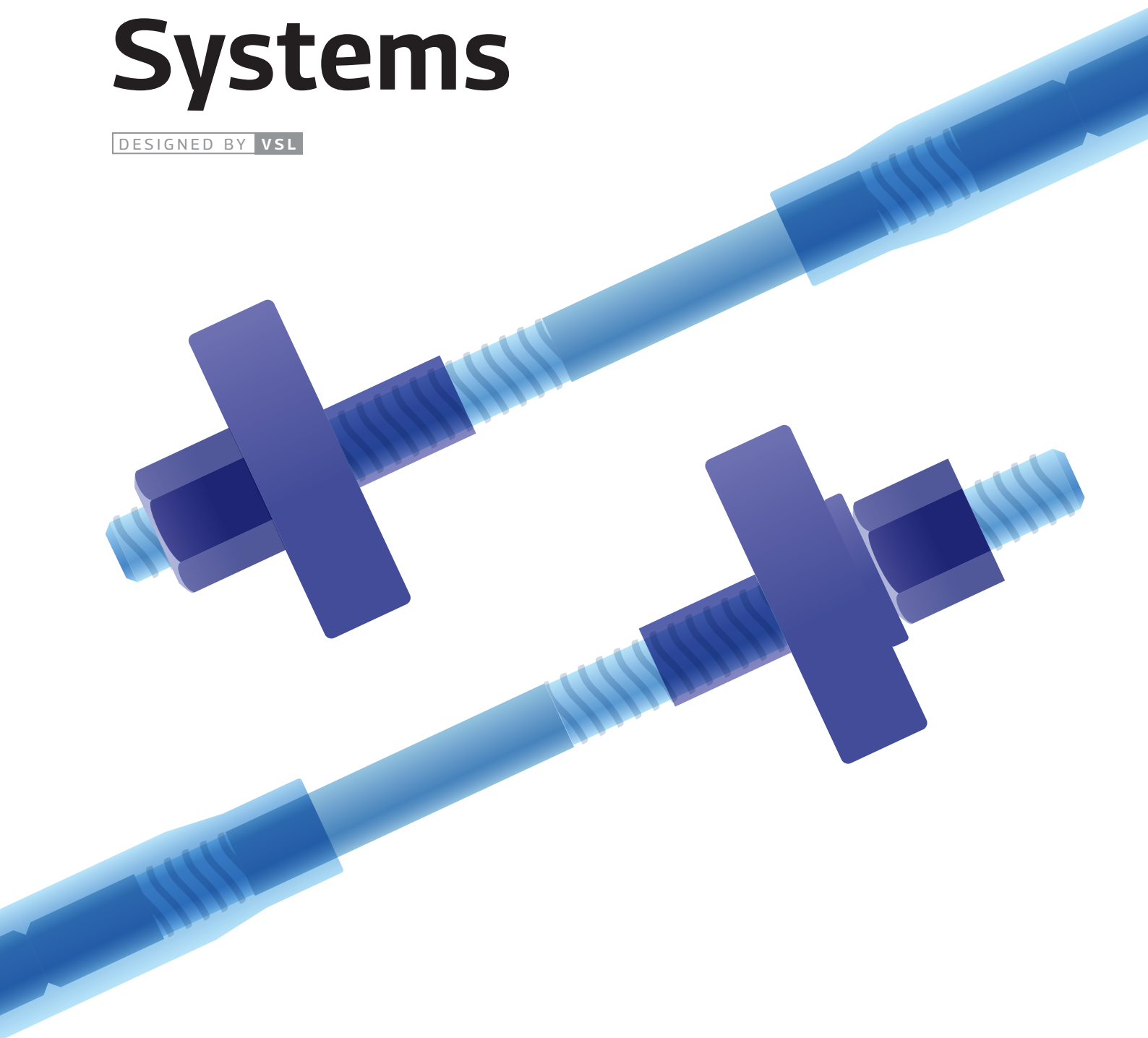

A member of
Bouygues Construction

March 2023

TECHNICAL CATALOGUE

TABLE OF CONTENTS

1	INTRODUCTION	4
	VSL CT Stress Bar grade Quality control VSL CT Stress Bar configurations	
2	APPLICATIONS	6
3	VSL CT STRESS BAR – GRADE 1030	8
	Steel properties Cold rolled threads Characteristics of VSL CT Stress Bar – grade 1030 Architectural component details (mm) Architectural tendon arrangement Standard component details (mm) Standard arrangement	
4	CORROSION PROTECTION	14
	CT Stress Bar – Grade 1030 Fittings and accessories	
5	VSL CT STRESS BAR – STRESSING EQUIPMENT	16
	Recess dimensions (mm) Jack clearance details (mm)	
6	HANDLING AND INSTALLATION RECOMMENDATIONS	18

1

Introduction

For over 50 years, VSL Australia Pty Ltd has been an industry leader in the design, supply and installation of superior post-tensioning products throughout Australasia and the Pacific Basin. The renowned VSL CT Stress Bar and its associated products have grown to meet Australia's expanding demand for high quality performance grade products.

The VSL CT Stress Bar system is comprised of high tensile heat treated bar. This system has particular attributes that make it more economical to use, compared to other forms of post-tensioning tendons of similar length. These attributes include:

- Bar tendons that are rigid and self-supporting and ideally suited to post-tensioning vertical elements.
- Threads and nuts that provide an anchorage that can be locked-off with minimal draw-in. This is particularly useful for short tendons.
- Coupling tendons that is simple and fast.

The VSL CT Stress Bar System is more economical compared with wire or strand systems when tendon lengths of less than 10 meters are being considered. This economical advantage is due to the system's relatively cost effective anchorage



VSL CT Stress Bar grade

Coarse Thread (CT) Stress Bars – Grade 1030 hot rolled and heat treated to comply with AS/NZS 4672 requirements of Elastic Modulus value $200 \pm 10 \text{ GPa}$. Standard diameter ranges available from $\text{Ø}26\text{mm}$ to $\text{Ø}75\text{mm}$.

The VSL proprietary CT thread is rolled onto the bar at VSL's facility in Australia.

Quality control

VSL Australia is accredited under a quality assurance system in compliance with the quality standard AS/NZS ISO 9001: 2015. Bars and anchorages comply with the requirements of international standards related to prestressing tendons and anchorages. The bars and anchorage components are tested for acceptance using a batch sampling procedure.

In addition to this, VSL Australia's CT Bar is also an accredited 'Australian Made' product, thus positioning it as a recognised and leading producer of Local Content, in support of key Australian Infrastructure Projects.



VSL CT Stress Bar configurations

VSL BAR SYSTEM	THREAD DETAILS					Architectural Components Available	Maximum Bar Length* m
	Full Thread	End Thread	Right-Hand Thread	Left-Hand Thread	Cold Thread		
26-56 CT Bar	•	•	•	•	•	•	12m
75mm Bar	–	•	•	•	•	•	12m

*5.85m length is recommended for 20ft container transport

*11.85m length is recommended for 40ft container transport

75mm CT Bar is supplied with 1000mm threaded ends as standard. Please consult with your local VSL supply source for other threaded length requirements.

2 Applications

VSL CT Bar System is ideal for the economic application of post-tensioning forces on relatively short tendons. Bar systems operate through threaded connections and anchorages, making them simple and easy to use in both prestressed and non prestressed applications. VSL bar systems are intended for axial tensile load applications only – bars have limited capacity for shear and or combined actions. Please consult your local VSL office for further advice where CT Stressbar are subject to combined actions. The Designer may also need to consider fatigue and other related behaviors for suitability in the intended project.

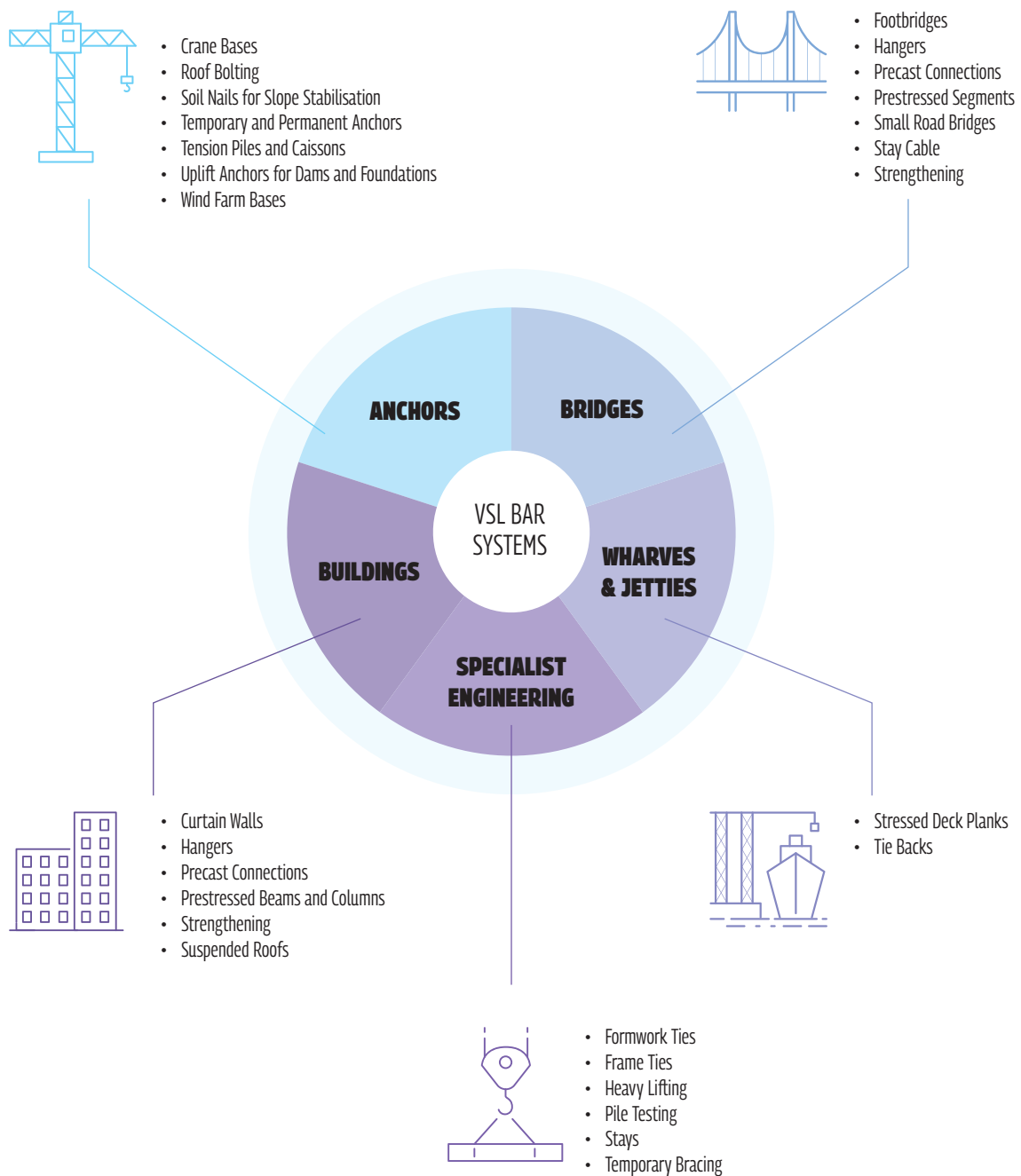

Please contact your local VSL office to discuss your application requirements with a VSL CT Stress Bar specialist.



5
6
7
8

MG 1
MG 1

7
8

3

VSL CT Stress Bar – grade 1030

Steel properties

VSL CT Stress Bars are hot rolled from high strength grade 1030 alloyed steel and heat treated using world class technology to obtain an Elastic Modulus value of 200 ± 10 GPa as per AS/NZS 4672, BS4486 and EN10138 specifications. The in-line single bar induction process ensures greater consistency in physical properties and stress-free straight bars.

Cold rolled threads

A coarse thread with 6mm pitch is cold rolled directly onto the bar. Bars can be supplied as follows:

- 1) CTS – 500mm End Threaded only (all sizes)
- 2) CTA – Fully Threaded (Please contact your local VSL supplier for 75mm)

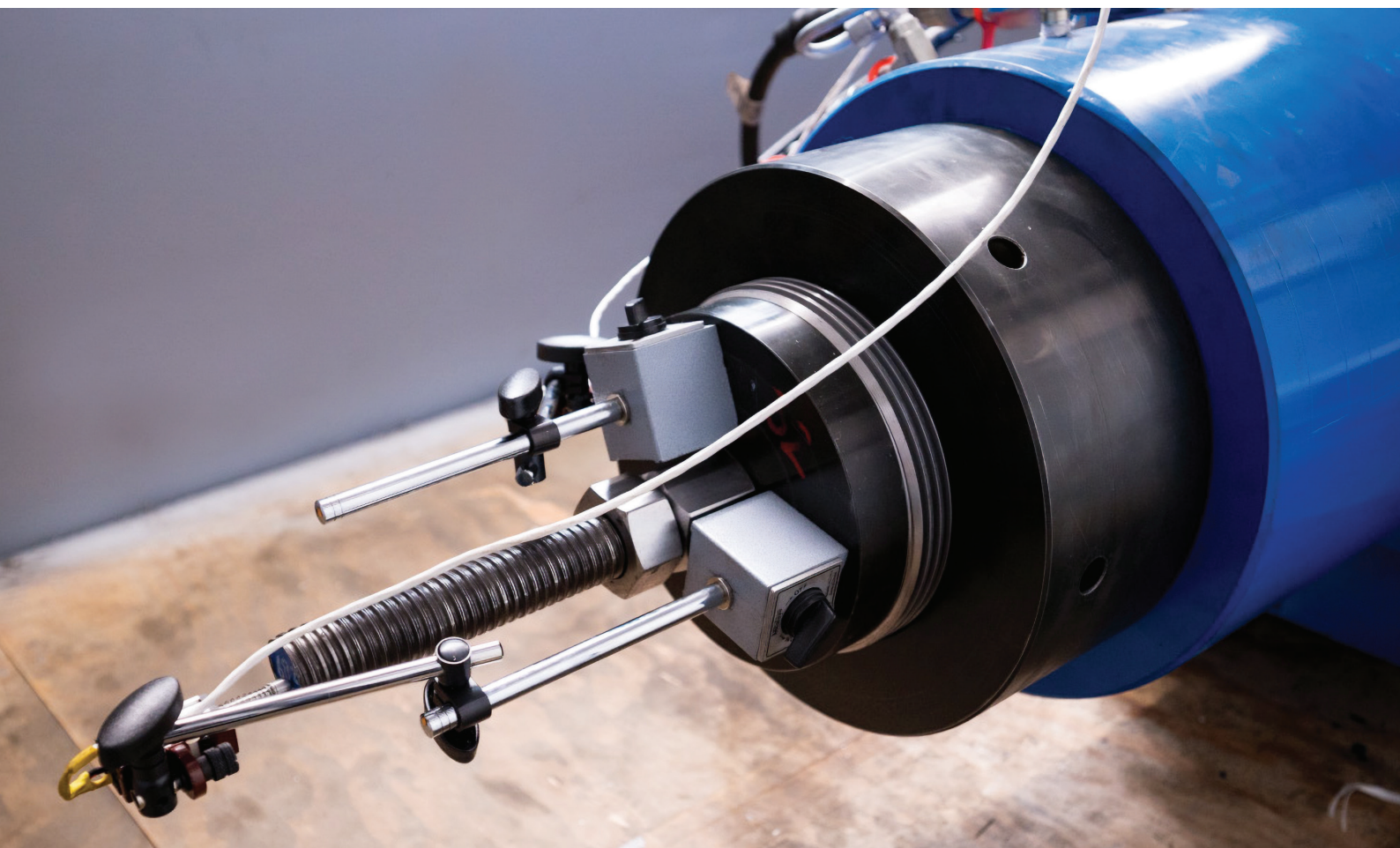

Characteristics of VSL CT Stress Bar – grade 1030

VSL CT Bar Size (mm)	Nominal Diameter of Bar (mm)	Nominal Bar Area (mm ²)	Nominal Mass (kg/m)	Nominal Tensile Strength (MPa)	Min Breaking Force (kN)	0.1% Proof Force (kN)	Minimum Elongation at max force %	Approx Modulus of Elasticity (GPa)	Thread Pitch (mm)	Major Thread Diameter (mm)	Minor Thread Diameter (mm)
26	27	562	4.41	1,030	579	469	6	200 ± 10	6	28.2	25.2
29	30	693	5.44	1,030	714	579	6	200 ± 10	6	31.2	28.2
32	33	840	6.59	1,030	865	702	6	200 ± 10	6	34.4	31.0
36	36	995	7.81	1,030	1,025	831	6	200 ± 10	6	37.4	34.0
40	40	1232	9.67	1,030	1,269	1,029	6	200 ± 10	6	41.4	38.0
48	48	1780	13.97	1,030	1,833	1,486	6	200 ± 10	6	49.5	46.1
56	56	2428	19.06	1,030	2,501	2,028	6	200 ± 10	6	57.7	54.3
75	75	4371	34.31	1,030	4,502	3,651	6	200 ± 10	6	77.5	72.7

Notes:

- Characteristic strength values meet the code requirements of AS/NZS 4672.
- 48mm diameter bar properties are in accordance with VSL specifications and meet the intent of the Australian standard as this size is not listed in AS/NZS 4672.
- Other sizes (up to 90mm) are available as a special order. Please consult your local VSL office regarding availability.
- Relaxation properties, as per AS 4672 are 4% maximum at 1000hrs when loaded to 70% of minimum breaking load.
- Minimum bend radius = 200 x bar diameter.
- Allow minimum 1mm draw-in for anchorage of bars on the standard nut at lock off.

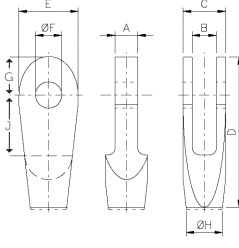
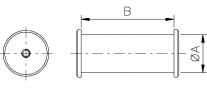
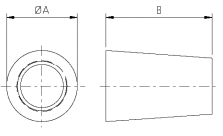
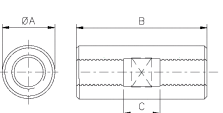

Architectural component details (mm)

ITEM	BAR DIAMETER	26	29	32	36	40	48	56	75	
	Spade Clevis	Part No	CLS26C	CLS29C	CLS32C	CLS36C	CLS40C	CLS48C	CLS56C	CLS75C
		A	36	40	40	45	50	55	80	100
	Forked Clevis	Part No	CLF26C	CLF29C	CLF32C	CLF36C	CLF40C	CLF48C	CLF56C	CLF75C
		B	39	43	43	48	53	58	83	103
		C	67	73	77	86	93	104	145	193
		D	240	254	277	294	330	363	412	542
		E	89	104	111	117	135	160	171	215
		F	37	40	43	46	57	61	76	101
		G	62	68	73	78	95	114	123	160
		H	50	56	65	70	80	90	110	140
J	88	95	109	116	131	148	154	222		
	Clevis Pin	Part No	CLP26C	CLP29C	CLP32C	CLP36C	CLP40C	CLP48C	CLP56C	CLP75C
		A	36	39	42	45	56	60	75	100
		B	68	74	78	87	94	105	146	194
	Conical Cover (Clevis)	Part No	LNC26S	LNC29S	LNC32S	LNC36S	LNC40S	LNC48S	LNC56S	LNC75S
		A	50	56	65	70	80	90	110	140
	Conical Cover (Coupler & Turnbuckle)	Part No	LNC26T	LNC29T	LNC32T	LNC36T	LNC40T	LNC48T	LNC56T	LNC75T
		B	90	100	110	110	120	140	160	210
	Turnbuckle Coupler	Part No	TC26R	TC29R	TC32R	TC36R	TC40R	TC48R	TC56R	TC75R
		A	50	56	65	70	80	90	110	140
		B	220	220	230	240	250	270	290	330
	C	120	120	120	120	120	120	120	120	

Architectural tendon arrangement

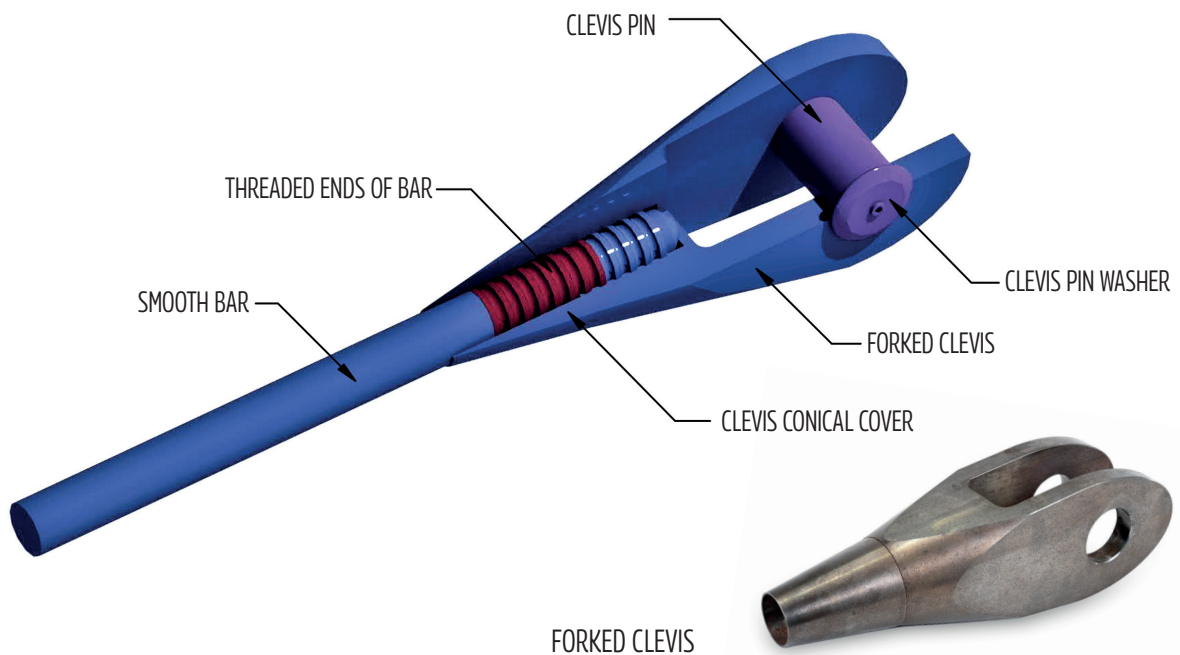

Standard component details (mm)

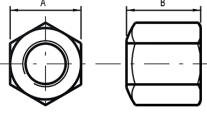
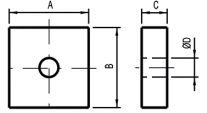
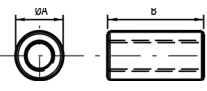
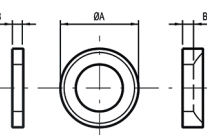
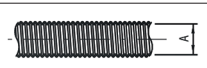
ITEM	BAR DIAMETER	26	29	32	36	40	48	56	75	
	Nuts	Part No	NC26	NC29	NC32	NC36	NC40	NC48*	NC56*	NC75*
		A	42	47	52	56	65	90	100	140
		B	50	55	60	65	70	60	70	90
	Locknuts	Part No	LNC26	LNC29	LNC32	LNC36	LNC40	LNC48	LNC56	LNC75
		B	22	24	27	29	32	39	45	60
	Bearing Plates	Part No	BP26	BP29	BP32	BP36	BP40	BP48	BP56	BP75
		A	130	150	150	150	180	250	250	300
		B	130	130	130	150	150	200	200	300
		C	32	40	50	50	50	70	70	75
		D	32	35	38	42	47	54	63	80
	Couplers	Part No	CC26	CC29	CC32	CC36	CC40	CC48	CC56	CC75
		A	45	48	54	60	66	78	88	120
		B	120	120	130	140	150	170	190	230
	Flat Washers	Part No	WF26	WF29	WF32	WF36	WF40	WF48	WF56	WF75
		A	56	60	66	72	84	100	120	150
		B	4	5	5	6	6	8	8	8
	Spherical Washers	Part No	WS26	WS29	WS32	WS36	WS40	WS48	WS56	WS75
		A	60	65	70	75	90	110	120	160
		B	10	10	10	10	12	12	18	20
	Ducting	Part No	D26	D29	D32	D36	D40	D48	D56	D75
		A	40	40	45	45	55	60	70	95

Notes:

- *Denotes the nuts for 48, 56 and 75mm. These nuts are supplied from round material with peg holes as standard.
- Dimensions may vary due to material availability at time of manufacture & material grade. Please consult your local VSL office where dimensional requirements are critical.
- BIM and architectural models of VSL CT Stressbar and components are available for use by engineers, specifiers and other consultants. Please consult your local VSL office.



Standard arrangement

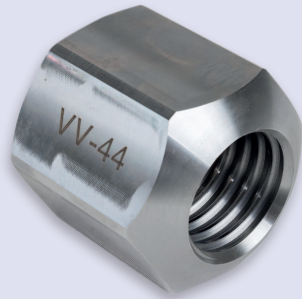

STANDARD HEXAGONAL NUT

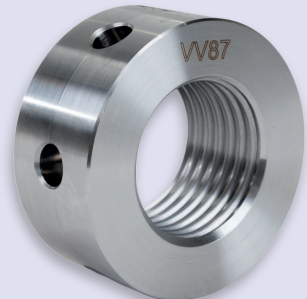

CIRCULAR LOCK NUT

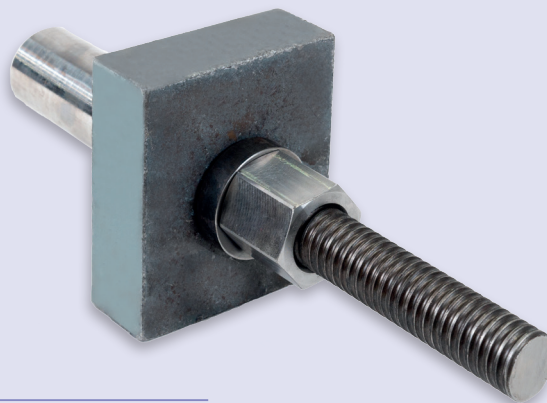
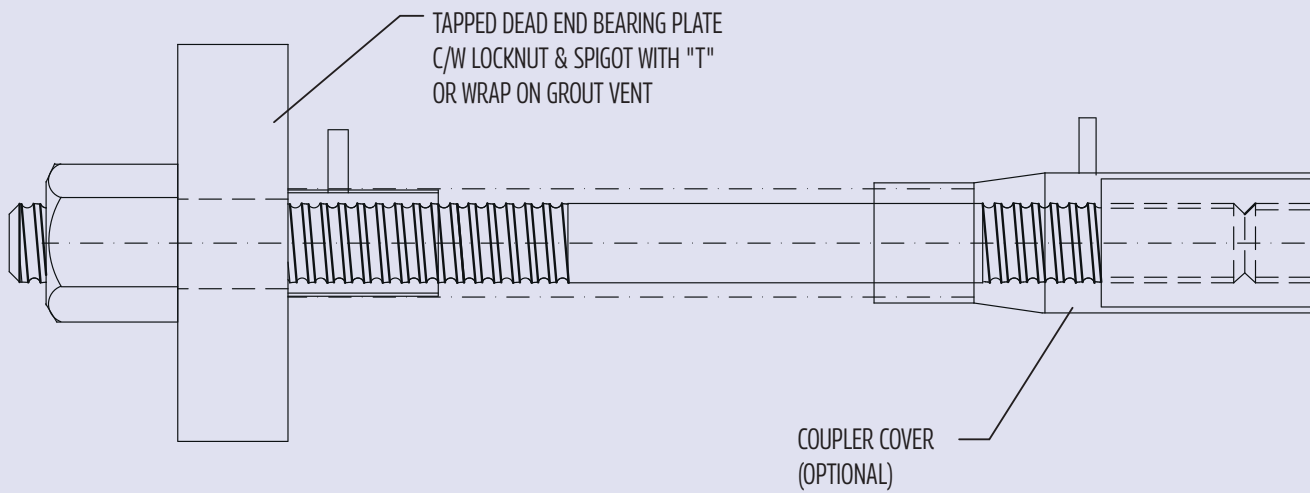

BEARING PLATE



CT COUPLER

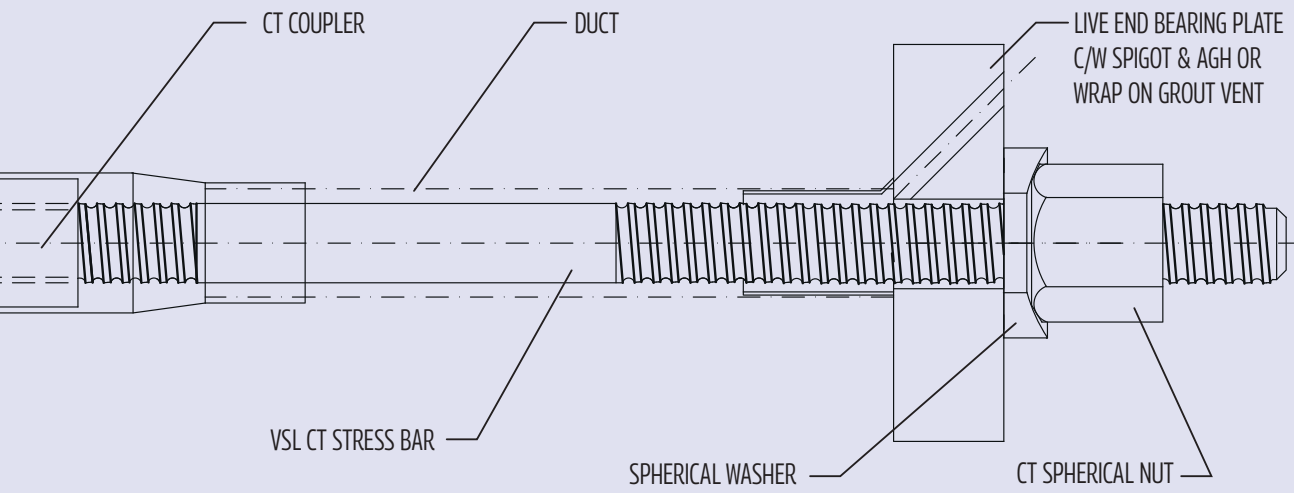

SPHERICAL WASHER & NUT

4

Corrosion protection

VSL CT Stress Bars and components must receive protection when installed under permanent conditions in an exposed environment. In standard concrete construction, the use of a galvanized duct injected with grout provides sufficient protection. Anchorage recesses must also be filled with cement mortar/epoxy to protect the ends. An alternative corrosion protection may be required for specific applications. VSL seek to provide the best forms of protection to meet usage and project specifications.

Coating specifications for a project will vary according to a large number of factors, both technical and economic. It is important to fully examine a potential coating to identify its durability performance before committing to a corrosion protection system. VSL recommend consultation with an experienced Corrosion Consultant during the design phase or when modifying any structural element. The following is a range of available systems that VSL has provided extensively since 1971.

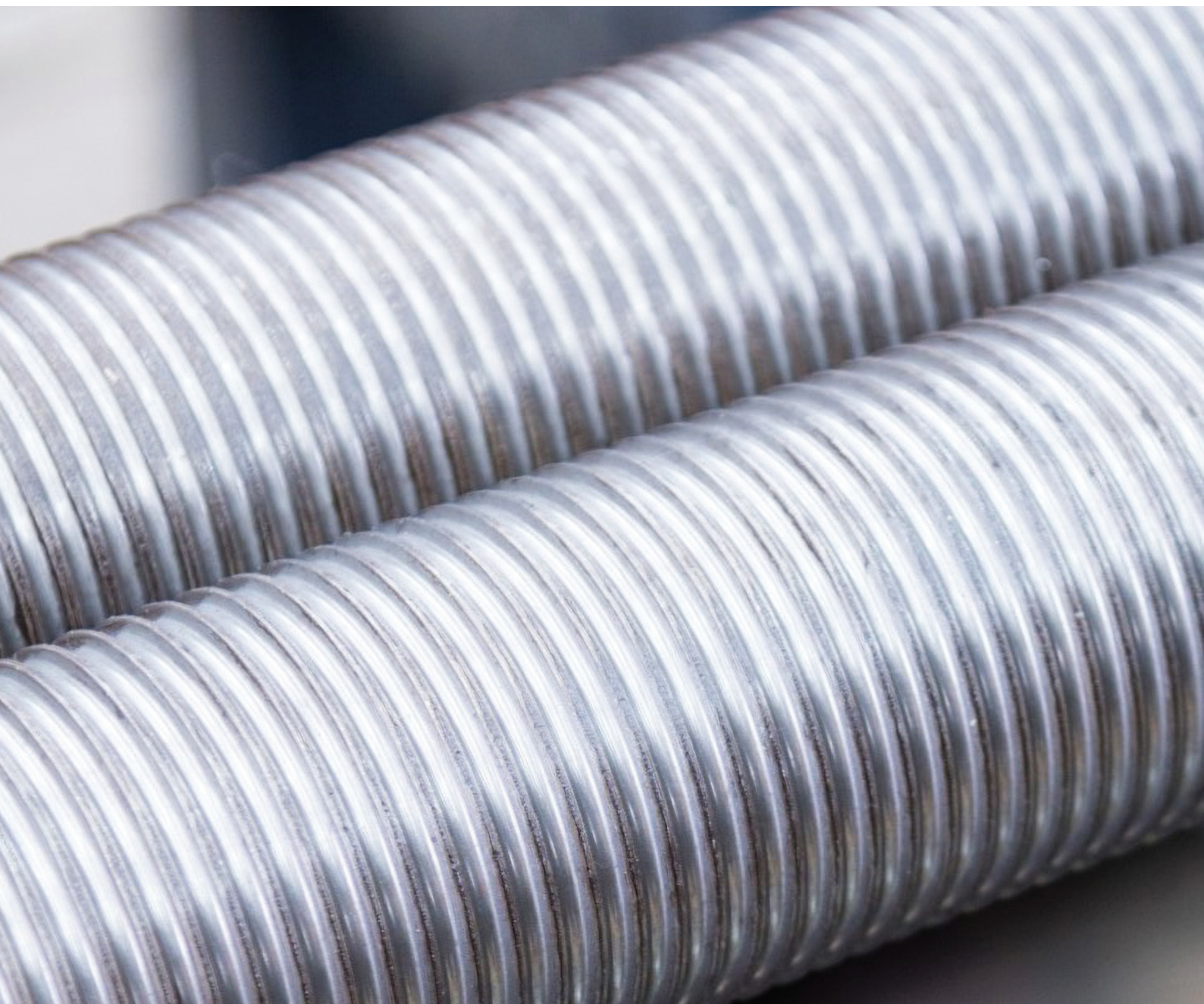

VSL CT Stress Bar – grade 1030

THREE COAT PAINT SYSTEMS

EPOXY COATING – a three coat epoxy system that is used for non-visual applications such as wharf ties, portal frames, frame connectors, water tanks, sewerage treatment plants, structure strengthening, holding down bolts, rock anchors, soil nails etc.

POLYURETHANE COATING – a three coat system comprising a single coat of primer and two top coats of polyurethane which give superior performance in relation to colour retention and reduction in chalking when exposed to atmospheric conditions.

GREASED AND SHEATHED IN POLYETHYLENE

Vertical bars used in water storage structures, free length of soil and rock anchors, wharf ties, hangers, cable stays, silos, remedial strengthening and all unbonded tendons. Depending on the application and anchoring detail, the ends of the PE pipe may be sealed with a suitable heat shrink sleeve to prevent ingress of moisture and/or escape of grease.

INORGANIC ZINC (IOZ)

An Inorganic Zinc Base Coating that protects steel galvanically. Applied as a single coat, it provides protection for steel structures exposed to weather and acts as a base coat for organic and inorganic top coats in more aggressive environments. This type of coating is used widely in environments such as refineries and coastal areas including offshore structures.

THE DENSO PETROLATUM/PCS PETROGARD SYSTEM

A long life corrosion protection system; this multi-component system remains permanently plastic and flexible and offers excellent conformability and longevity. The system provides 100% uniform coverage and unrivalled corrosion protection in terms of surface preparation requirements and ease of application.

THERMAL DIFFUSION GALVANISING

This metallurgical vapour diffusion process is used to apply a uniform, sacrificial, zinc-iron coating to ferrous and certain non-ferrous materials. The corrosion-resistant and abrasion-resistant coating helps to increase durability in harsh environments. 85µm of thickness is recommended by the specialist applicator.

Fittings and accessories

VSL CT Stress Bar Components can be protected by one of the following methods.

- Hot Dip Galvanized to Min 40µm as per the Australian Standard AS/NZS 4680
- 3 Coat Paint Systems/Inorganic Zinc (IOZ)
- Mechanical Plating (Galvacoat) – 40µm coating of zinc equivalent to AS/NZS 4680 or AS/NZS 1214. The process avoids potential for hydrogen embrittlement.

NOTE: threads are re-tapped after the corrosion protection process to ensure thread is viable during assembly.

Corrosion Protection System	Indicative Years to First Maintenance – Expected Min to Max.					
	Atmospheric Corrosivity Categories					
	C1 Very Low	C2 Low	C3 Medium	C4 High	C5 Very High	Cx Extreme
Bonded PT Tendon (Cement Grout)	25+	25+	25+	25+	25+	25+
Wax/ grease with PE sheathing	25+	25+	25+	25+	25+	25+
Three Coat Paint system : Epoxy	25+	15-25+	10-25+	5-25+	2-25	Seek advice
Three Coat Paint system : Polyurethane	25+	10-25+	5-25+	2-25+	2-25	Seek advice
Inorganic Zinc	25+	25+	15-25	10-15	2-5	Seek advice
Petrolatum Impregnated tapes or similar	25+	25+	25+	10-25+	5-25+	5-25
Thermal Galvanised	25+	25+	25+	10-25+	5-25+	2-15
Hot Dip Galvanising (Components only)	25+	25+	25+	10-25+	5-25+	2-15

Notes:

- Atmospheric Corrosivity Categories are in accordance with AS 2312:2014.
- All information contained herein is indicative only and shall be used as a guide for initial suitability assessment. VSL recommend guidance is sought from a specialist durability consultant for Atmospheric Corrosivity Categories equivalent to C4 and above.
- Years to first maintenance are dependant on the details of the coating systems (surface preparation, product selection, thickness etc). Contact your local VSL Technical Centre for further advice on specific applications.
- Category Cx is associated with very high salt deposition or severe acidic industrial environments. These conditions typically require bespoke three-coat paint protection system design.
- Inorganic Zinc information provided on the basis of a single coat application. Special precautions are required when used in conjunction with other topcoat systems.

5

VSL CT Stress Bar – stressing equipment

Recess dimensions (mm)

BAR DIAMETER	A	B	C	K
26	175	175	145	160
29, 32, 36	195	195	160	180
40	225	195	170	200
48	295	245	210	230
56	295	245	240	290
75	345	345	260	340

Jack clearance details (mm)

JACK MODEL	F**	G	H	J
B55	1000	95	125	250
B90	1000	105	150	250
B90L	1000	105	150	250
B100	1000	110	150	250
B100L	1000	110	150	250
B150	1000	150	150	250
B200	1025	160	200	460
VSL190	1600	220	200	460
VSL460	1600	260	250	580

** Denotes dimensions based on standard pull bar length. Reduced dimensions may be possible. Please contact your local VSL office.

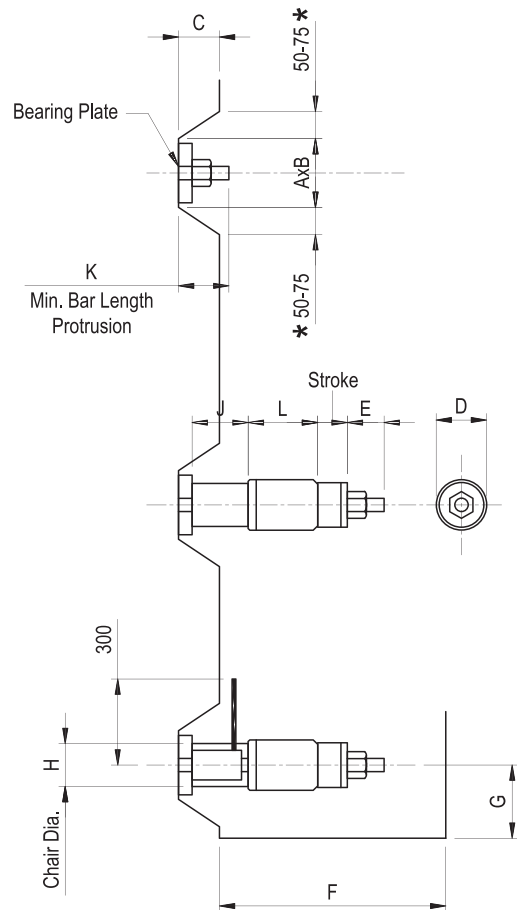

* denotes 50 for 40 diameter and small bars; 75 for bars larger than 40 diameters.

NOMINAL BAR DIAMETER	JACK MODEL	JACK DIMENSION				CAPACITY [kN]	WEIGHT [kg]
		D	L	E	STROKE		
26	B55	165	245	85	125	550	33
29, 32, 36	B90	190	280	105	80	900	48
29, 32, 36	B90L	190	355	105	150	900	62
40	B100	200	170	130	50	1000	28
40	B100L	200	270	130	150	1000	48
48	B150	275	300	150	150	1500	100
48, 56	B200	300	380	170	150	2000	160
56	VSL190	410	565	220	100	1900	151
75	VSL460	485	510	220	100	4600	425





6

Handling and installation recommendations

- VSL CT Stress Bar MUST NOT be welded under any circumstances. All bars must be isolated and insulated against stray currents, electrical arcing, as well as localised heating, splashing with weld metal or grinding sparks. If welding is to take place in the vicinity of the bars, please ensure that the elements being welded are satisfactorily earthed as close as possible to the site of welding.
- Please consult a Welding Specialist if you are considering welding in the vicinity of the bars. During handling, care should be taken to avoid local damage or bending.
- The use of Roller Supports or similar makes the threading on of fittings easier and minimises potential bar and thread damage.
- The use of a lifting beam or multiple suspension points should be considered for the installation of long bar assemblies in order to minimise induced bending.
- If stored externally, the bars should be protected from the elements using temporary covers. It is recommended that bars and their components are stored systematically to facilitate traceability. The use of a soluble oil, such as Dromus, as a rust inhibitor coating is recommended for extended storage periods.
- All bar and component threads must be inspected and cleaned before assembly. Any superficial damage can be repaired by experienced personnel. Please contact your local VSL office for details.
- Light rusting is not harmful to the bars however deep pitting corrosion must be avoided.
- Bars MUST be engaged to the midpoint of all standard couplers.
- Vibration may cause nuts and fittings to loosen. Lock nuts are available to mitigate against possible loosening effects.
- Developing and measuring a nominated tensile load in a bar is best performed using a calibrated centre hole jack.
- Bars can be stressed via alternative applied torque methods. Evaluation of the actual applied tension is recommended.
- Small elongation of short bars under load, accurate determination of thread take up and limited accuracy in general field measurement, means that the reliance on elongation as a control in tensile force determination is limited.
- The proper installation, stressing and grouting of high tensile steel bars is critical for ensuring their long term performance. VSL recommends engaging experienced, trained personnel to manage this process to ensure performance, durability and OH&S requirements.
- When grouting, consideration needs to be exercised to allow and compensate for any grout bleed particularly for long, vertical bars.
- Consideration should be given to sealing of completed assemblies for corrosion protection.

Copyright 03/2023, VSL International Ltd.

This document is the property of VSL International and must not be copied, reproduced, duplicated nor disclosed totally or partially to any Third Party, nor used in any manner whatsoever without prior written consent of VSL International Ltd. Please note all specifications featured in this brochure are current at the time of publication. The information set forth in this brochure including technical and engineering data is presented for general information only. While every effort has been made to insure its accuracy, this information should not be used or relied upon for any specific application without independent professional examination and verification of its accuracy, suitability and applicability. Anyone using this material assumes any and all liability resulting from such use. VSL disclaims any and all express or implied warranties of merchantability fitness for any general or particular purpose or freedom from infringement of any patent, trademark, or copyright in regard to the information or products contained or referred to herein. Nothing herein contained shall be construed as granting a license, express or implied under any patents.

VSL, a member of Bouygues Construction, is an expert in advanced construction methods and technologies, using them to design, build and repair road & rail infrastructure, underground structures, buildings and energy production structures. VSL brings tailor-made and creative solutions to each project, from engineering to execution, to successfully resolve its clients' most complex challenges.



Keep in touch with VSL on [vsl.com](https://www.vsl.com) and [in](#) VSL International Ltd.